

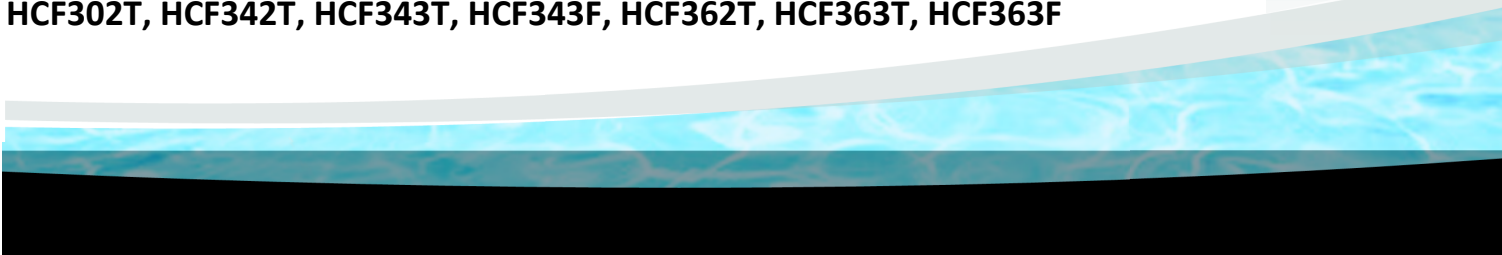

COMMERCIAL SAND FILTER MANUAL

**Models:**

**HCF302T, HCF342T, HCF343T, HCF343F, HCF362T, HCF363T, HCF363F**



## Table of Contents

1. Important Safety Instructions
2. General
  - 2.1 Swimming Pool Filters
  - 2.2 Hayward® Filters
  - 2.3 Selection of Filters and Installation
    - 2.3.1 Filter Characteristics
    - 2.3.2 Installation Characteristics
    - 2.3.3 Piping Connection Kits
3. Characteristics and Dimensions
  - 3.1 Dimensions
4. Installation
  - 4.1 General Installation Notes
  - 4.2 Filter Installation
  - 4.3 Installation of the Pressure Gauge
  - 4.4 Removing the Filter Manway Cover
  - 4.5 Re-Installation of the Manway Cover
  - 4.6 Testing of Filter
  - 4.7 Installation of the Sand
5. Normal Operation
  - 5.1 Filtration
  - 5.2 Backwash
  - 5.3 Close/ Isolate
6. Changing of the Sand
7. Winterizing
8. Graph of Filter Head Loss
9. Replacement Filter Parts List
10. Warranty
11. Product Registration
12. Warranty Card Registration





**Commercial Sand Filter**

**Models: HCF302T, HCF342T, HCF343T,  
HCF343F, HCF362T, HCF363T, HCF363F**

# 1. Important Safety Instructions

Basic safety precautions should always be followed, including the following: Failure to follow instructions may result in injury.

 This is the safety-alert symbol. When you see this symbol on your pump or in this manual, look for one of the following signal words, and be alert to the potential for personal injury.

 **WARNING** warns about hazard that could cause serious personal injury, death or major property damage and if ignored presents a potential hazard.

 **CAUTION** warns about hazards that will or can cause minor or moderate personal injury and/or property damage and if ignored presents a potential hazard. It can also make consumers aware of actions that are unpredictable and unsafe.

The NOTICE label indicated special instructions that are important but not related to hazards.





**WARNING – Read and follow all instructions** in this owner's manual and on the equipment. Failure to follow instructions can cause severe injury and/ or death.

 **WARNING** – This product should be installed and serviced only by qualified professionals.

 **CAUTION** – All electrical wiring **MUST** be in conformance with all applicable local codes, regulations, and the National Electrical Code (NEC).

 **WARNING** – To reduce risk of injury, do not permit children to use or climb on this product. Closely supervise children at all times. Components such as the filtration system, pumps, and heaters must be positioned to prevent children from using them as a means of access to the pool.

 **WARNING** – Pool and spa components have a finite life. All components should be inspected frequently and replaced at least every seven years, or if found to be damaged, broken, cracked, missing, or not securely attached.

 **WARNING** – Suction Entrapment Hazard. Suction in suction outlets and/ or suction outlet covers, which are damaged, broken, cracked, missing, or unsecured cause severe injury and/ or death due to the following entrapment hazards (symbols compliments of APSP):



**Hair Entrapment** – Hair can become entangled in suction outlet cover.

**Limb Entrapment** – A limb inserted into an opening of suction outlet sump or suction outlet cover that is damaged, broken, cracked, missing, or not securely attached can result in mechanical bind or swelling of the limb.



**Body Suction Entrapment** – A differential pressure applied to a large portion of the body or limbs can result in an entrapment.



**Evisceration/ Disembowelment** – A negative pressure applied directly to the intestines through an unprotected suction outlet sump or suction outlet cover which is damaged, broken, cracked, missing, or unsecured can result in evisceration/ disembowelment.



**Mechanical Entrapment** – There is potential for jewelry, swimsuits, hair decorations, fingers, toes, or knuckles to be caught in an opening of a suction outlet cover resulting in mechanical entrapment.



**WARNING – To Reduce the Risk of Entrapment Hazards:**

- When outlets are small enough to be blocked by a person, a minimum of two functioning suction outlets per pump must be installed. Suction outlets in the same plane (i.e. floor or wall), must be installed a minimum of three feet (3') (.91 meter) apart, as measured from near point to near point.
- Dual suction fittings shall be placed in such locations and distances to avoid “dual blockage” by a user.
- Dual suction fittings shall not be located on seating areas or on the backrest for such seating areas.
- The maximum system flow rate shall not exceed the values shown in the “Pipe Sizing Chart” found on page 14.
- Never use pool or spa if any suction outlet component is damaged, broken, cracked, missing, or not securely attached.
- Replace damaged, broken, cracked, or not securely attached suction outlet components immediately.
- In addition to two or more suction outlets per pump installed in accordance with latest APSP standards and CPSC guidelines, follow all national, state, and local codes applicable.
- Installation of a vacuum release or vent system, which relieves entrapping suction, is recommended.



**WARNING – Hazardous Pressure.** Pool and spa water circulation systems operate under hazardous pressure during start-up, normal operation, and after pump shut-off. Stand clear of circulation system equipment during pump start-up. Failure to follow safety and operation instructions could cause property damage, severe personal injury, or death. Before servicing pool and spa water circulation system, all system and pump controls must be in off position and filter manual air relief valve must be in open position. Before starting system pump, all system valves must be set in a position to allow system water to return back to the pool. Do not change filter control valve position while system pump is running. Before starting system pump, fully open filter manual air relief valve. Do not close filter manual air relief valve until a steady stream of water (not air or air and water mix) is discharged from the valve. All suction and discharge valves **MUST** be OPEN when

starting the circulation system. Failure to do so could result in severe personal injury and/ or damage.



**WARNING – Separation Hazard.** Failure to follow safety and operation instructions could result in violent separation of pump components. Strainer cover must be properly secured to pump housing. Before servicing pool and spa circulation system, all system and pump controls must be in off position and filter manual air relief must be in open position. Do not operate pool and spa circulation system if a system component is not assembled properly, damaged, or missing. Do not operate pool and spa circulation system unless manway cover is in seated position in filter body. All suction and discharge valves **MUST** be OPEN when starting the circulation system. Failure to do so could result in severe personal injury and/ or property damage.



**WARNING** – Never operate or test the circulation system at more than 50 PSI maximum.

**WARNING** – Failure to install according to defined instructions may result in severe personal injury or death.



**WARNING – ELECTROCUTION HAZARD.** High voltage electricity is present in the pool and spa equipment. High voltage electricity can cause shock and electrocution. Shock and electrocution can result in severe personal injury or death.

- All electrical wiring **MUST** be in conformance with applicable local codes, regulations and the National Electrical Code (NEC).
- Before performing any service or maintenance on electrical equipment turn off all electrical power.
- Contact a licensed electrician or building inspector for information on local electrical codes for bonding requirements.
- Verify water discharge from the filter manual air relief valve is directed away from electrical devices.
- Do not locate pump controls over or near filter.

## 2. General

▲ NOTICE – Each country (possibly each state) will have its own standards for public and private pools. It is the responsibility of the installer to be aware of these codes before designing, specifying or installing any piece of equipment for a swimming pool.

### 2.1 Swimming Pool Filters

Filters are, without a doubt, the most important accessory used in the treatment of swimming pool water. Their purpose is to eliminate suspended particles from the circulating water, thus clarity of the water.

The principle operation consists of passing the swimming pool water through a bed of sand which will retain any particles that are suspended in the water.

It should be kept in mind that the filtration system consists of a number of elements, such as metering equipment, pumps, pool shell fittings and pipe work, which ensure the correct suction and return flows that will affect the resultant condition of the treated water.

The quality of filtration depends on various factors, the size and shape of the sand, the sand bed depth, characteristics of the sand such as granular size, density, etc. A most important parameter is the water filtration rate. Other factors affecting the selection of a filter are the materials used for its construction, the working temperature, and the operating pressure.

### 2.2 Hayward® Filters

Manufactured from proprietary resins and fiberglass, they are virtually corrosion-proof. The internal fittings (diffuser and lateral system) are manufactured from PVC and ABS. They are unaffected by salt water and are manufactured for a working pressure up to 50 PSI and a maximum working temperature of 122° F.

### 2.3 Selection of Filters and Installation

#### 2.3.1 Filter Characteristics

Choose the filter or filters that meet the local turnover time requirements. Remember it is possible to add filters together to obtain the correct amount of filtration area required. Note: when using multiple filters, they must be plumbed in parallel configuration. It is also a good idea to oversize the surface area required by 10% or more, this will allow for better water quality. When possible, use more than one filter in conjunction, this will allow one filter to be serviced while one is still functioning.

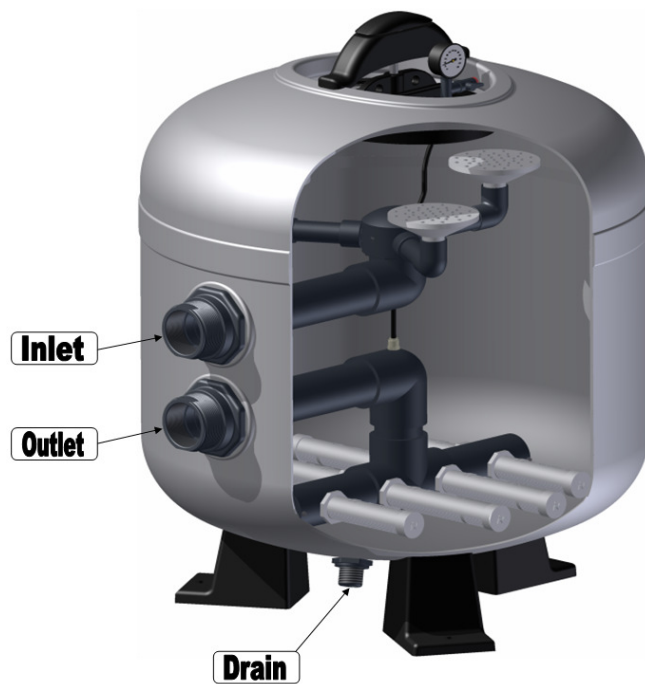

When sizing the plumbing for a filtration package be sure to keep in mind that the velocity of the water in the pipes is very important. Each country or state may have different maximums for velocity in the plumbing. The recommendations of APSP-7 should be followed.

### 2.3.2 Installation Characteristics

To insure selection of the correct pump size, the required flow must be obtained by taking the system head into consideration. The system head is the added difficulty to move water through the system presented by using, elbows, piping, tees, changes in elevation, etc.

It is also recommended that the discharge from each pump is brought together in a single manifold to the filters. This will allow for greater flow rates for the backwash cycle.

- Install a check valve ahead of filter inlet to prevent contaminants from draining back into the pool.
- Install a check valve between filter and heater to prevent hot water from backing up into filter and damaging internal components.
- Disposal of “waste water” must meet local, state and national codes.
- See Chart on Page 8 for vertical and horizontal clearance.

### 2.3.3 Piping Connection Kits

Hayward Recommended Filter Piping Connections:				
Filter Model:	Port Size	Multi-Port Valve	Piping Kit	Flange P/N
HCF302T	2"	HCV275	W/ Valve	N/A
HCF342T	2"	HCV275	W/ Valve	N/A
HCF343T	3"	HCV375	HCV375KIT	N/A
HCF343F	3"	N/A	N/A	HCF375KIT
HCF362T	2"	HCV275	W/ Valve	N/A
HCF363T	3"	HCV375	HCV375KIT	N/A
HCF363F	3"	N/A	N/A	HCF375KIT

# 3.Characteristics and Dimensions

## 3.1 Dimensions and Sand Requirements

Use only High Rate Sand No. 20 Silica Sand (.45mm - .55mm)

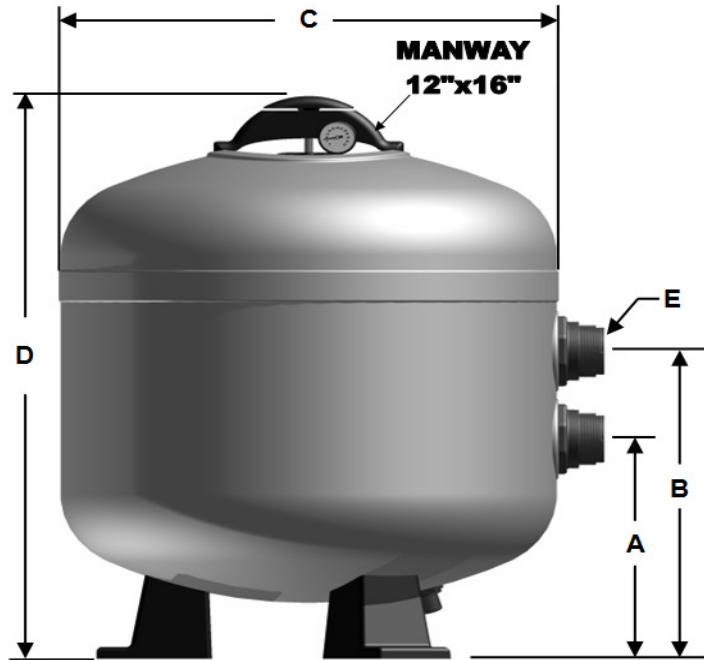

Figure 3-1

Filter Model Number	Dimensions (Inches)					Filter Area		Max Flow Rate		Filter Sand Qty (Lbs)	Clearance (Inches)	
	A	B	C	D	E	Sq. Ft.	Sq. M	GPM	LPM		Vertical	Horizontal
HCF302T	16.5	24.0	30.63	42.5	2	4.9	.46	98	371	650	42.5	30.0
HCF342T	18.75	26.25	34.5	47.5	2	6.3	.59	126	477	950	47.5	34.0
HCF343T	18.75	26.25	34.5	47.5	3	6.3	.59	126	477	950	47.5	34.0
HCF343F	18.5	26.22	34.5	47.5	3	6.3	.59	126	477	950	47.5	34.0
HCF362T	18.75	26.25	37.0	48.5	2	7.16	.67	143.2	542	1050	48.5	36.25
HCF363T	18.75	26.25	37.0	48.5	3	7.16	.67	143.2	542	1050	48.5	36.25
HCF363F	18.5	26.22	37.0	48.5	3	7.16	.67	143.2	542	1050	48.5	36.25



## 4. Installation



**WARNING** – Read and follow all Instructions.

### 4.1 General Installation Notes



**WARNING** – *This product should be installed and serviced only by a qualified professional.*

**Note:** Filters are supplied in a box and on a pallet with accessories included. Due to their weight and size it is recommended that mechanical means be employed to move the filter into position. It is also very important to inspect the filters carefully before installing. Make note on the shipping paperwork if there is any damage to the packaging. FRP filters can be damaged during transportation and it is the responsibility of the installer to inspect at the time of delivery.

Damages to filters from transportation that are not noted on the bill of lading are not covered by Hayward's warranty policy and all costs to repair will be the responsibility of the owner.

Never put the sand into the filter until it is in its final working position and all prior steps are complete.

The filter should be accessible for periodic maintenance or media change. It is absolutely necessary to leave a minimum access space around the filter(s), as defined on page 8.

The equipment room should be well ventilated and provided with adequate drainage capabilities so that should an emergency occur, resulting in flooding from a pipe, filter or pump, the water can be easily removed to avoid property damage. If drainage cannot be supplied directly from the equipment room, consideration should be given to the installation of alternate system to remove water from the mechanical room, per federal, state and local codes.

### 4.2 Filter Installation

Move the filter(s) into place using whatever means available. Do not use the manway cover or opening to maneuver the filter. Be sure to use care if moving by hand. Before continuing, be sure that the filter(s) are in the desired location with the connections facing the direction necessary for proper installation. It is also very important to make sure that the filter is sitting on a level, hard surface.

It is possible that during transportation, some internal components have loosened. It will be necessary to remove the filter manway cover and enter the filter, being careful not to break any of the connections. By hand, check the tightness of all the laterals in the bottom of the filter making sure they are firmly tightened.

## 4.2.1 Tank Positioning

Chalk lines are recommended for multiple tank installations and should be laid for positioning each tank.

Attention must be paid to the location and routing of the influent, effluent and waste line plumbing when planning the proper location of the filter system. The tanks must be level and parallel to each other or damage may occur to filter tanks, operating valves or connecting piping.

Anchor bolts, nuts and flat washers can be purchased. Anchor bolts must be installed and secured to comply with the requirement of specific seismic zones. If the filter room floor is not level, shims must be used to level the tanks or the face piping plumbing connections may break or leak.

### 4.2.1.1 Positioning Tank

Position the tank in the desired location, drill anchor bolt holes, and install anchor bolts, washers and nuts. Tighten nuts to secure filter system.

## 4.3 Installation of the Pressure Gauge

The pressure gauge assembly will come in a bag hanging from a diffuser within the filter. Remove all the parts from the bag and apply Teflon tape to all threaded connections. Thread the pressure gauge (1) into gauge tee (2). Screw vent valve (3) into other side of the gauge tee (2). Thread long nipple (4) into gauge tee (2) and into manway cover (5).

Once the system is started, open vent valve (3) to bleed any air that might have been trapped in the filter during startup.

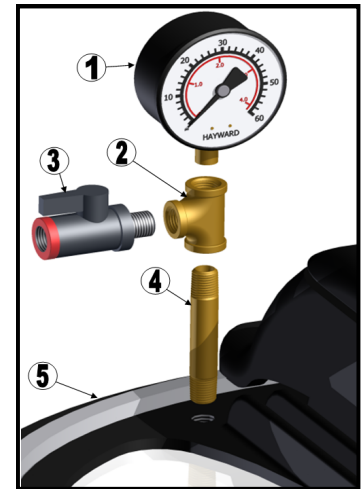

1- Pressure Gauge

2 – Gauge Tee

3 –Vent Valve

4 – Long Nipple

5 – Manway Cover

#### 4.4 Removing the Manway Cover

**WARNING**  This product should be installed and serviced only by a qualified pool professional. Your filter comes with a filter manway cover pre-installed from the factory.

*For qualified pool professionals only: If filter manway cover needs to be serviced, follow these instructions carefully.*



1. Turn off all system circulation pumps and all electrical power in the equipment controls.
2. Set all system valves in a position to prevent water from flowing to the filter.
3. The manual air bleed valve (vent valve) must be placed in the OPEN position.
4. Wait until all water leakage has stopped.
5. While holding the manway cover by the finger holes, rotate the knob portion of the manway cover yoke counterclockwise until released from the manway cover.
6. Push the manway cover into the filter tank, rotate cover.
7. Remove the manway cover from the tank, a slight rocking motion may be required to clear the internal piping in the filter tank

#### 4.5 Re-installation of the Manway Cover

1. Check the seals, replace as needed.
2. With a clean cloth, wipe upper filter body manway seat. Remove all dirt and debris.
3. Insert the manway cover into the filter tank, hold the manway cover by the finger holes.
4. Rotate the manway cover into position, a slight rocking motion may be required to clear internal piping in the filter tank.
5. Reseat the manway cover into filter tank, make sure seal is inserted in groove all around manway cover and making contact with filter tank manway seat for full surface of seal.
6. Attach knob bolt to manway cover ensuring proper insertion through yoke and proper seating of yoke onto flat areas of filter tank bezel.
7. Rotate knob portion of the manway cover yoke clockwise to energize seal.
8. Verify the air bleed discharge points away from all electrical connections.

## 4.6 Testing Filter

Before adding any sand to the filter, it is very important to test the system with water only. All filters are tested with high pressure before leaving the factory. It is important to test the system without sand first, to check for leaks. Open the vent valve. Fill the system with water. When water stream, not water and air, is discharged from the vent valve, close vent valve. Run system as normal and check for leaks. If there is a problem with the test, contact Hayward customer service immediately. If sand is added before the test and there is a problem with the filter, the sand will need to be evacuated in order to inspect for potential damage. Hayward® will not be responsible for the removal and replacement of the sand for warranty or repair work, nor will Hayward provide labor to evacuate and replace the sand for repair work done due to transportation or installation damage. This is also a good chance to check all of the plumbing for the system. Do not drain the water from the filter after the testing sequence.

## 4.7 Installation of the Sand

**WARNING**



After testing has been finished and the system is 100% operational, add the filtration sand required. Use #20 silica sand (.45 - .55 mm). Open the vent valve, remove the manway cover and seal from the filter. See section 4.4 (page 11). Ensure the filter is full of water up to the inlet port. The proper amount of sand is listed in Fig. 3-1, page 8. If a diffuser head is directly underneath the manway opening, cover it with plastic and tape to prevent sand from entering the plumbing.

**Notice** - Remove any plastic and tape from the diffuser after the sand is poured in the filter and before starting the system.

Now, replace the manway cover and seal into the filter tank. See section 4.5 (page 11). Be sure that the manway cover is free of debris. If the manway cover is not free of sand, the seal will not seat properly and could cause the filter to leak at the manway cover. Use the vent valve to remove air from the filter. Put the filter valves into the backwash mode, turn the pump ON, (see next section) and run for about 3 to 5 minutes. This will level the sand inside the filter. Turn pump OFF, put the valves into filter position and the system is ready for operation.

# 5. Normal Operation

## 5.1 Filtration

Note: Hayward Commercial offers a complete line of valves and connection kits for the Hayward line of Commercial Pool Filters.

Use the Hayward 2" Multi-Port valve (HCV275) for the HCF302T, HCF342T, HCF362T filters.

Use the Hayward 3" Multi-Port valve (HCV375) for the HCF343T and HCF363T filters. Use the Hayward 3" Flange Kit (HCF375KIT) for the HCF343F and HCF363F filters. See Table 2.3.3 (Page 7).

With the pump turned OFF, arrange the valve(s) for filtration. Start pump, open air relief vent valve until solid stream of water is coming out. Close the vent valve and read the pressure gauge. This is the normal start up pressure when the filter sand is clean. Make a note of the start up pressure.

When the pressure gauge shows a pressure rise of 8 to 12 psi above the start up pressure, it is time to backwash the filter.

## 5.2 Backwash

 **CAUTION** – Check the water level in the skimmer opening before and after backwashing. Replace water after backwashing to at least 2 inches above the bottom of the skimmer opening.

To backwash the filter, stop the pump, set the valve(s) into the “Backwash” position and restart the pump. The backwash cycle should be run for 3 to 5 minutes. Once backwash is complete, turn pump off and set valve(s) to the “Filter” position and start pump.

 **NOTICE**- It is very important to turn off the filter pump(s) prior to changing valve(s) position.

## 6. Changing of the Sand

The procedure for changing the filter sand is as follows:

1. **WARNING**  Turn pump(s) OFF. Open vent valve. Close necessary valves to isolate filter.
2. Remove manway cover and seal from filter. See section 4.4. Open drain port to drain the water from the filter.
3. Using a shop vacuum or a small bucket remove the sand.
4. Using a hose, spray the sand to loosen if necessary.
5. Clean remaining sand from the walls as best as possible with a hose and vacuum.
6. Add the new sand as required in Figure 3-1 (Page 8) of this manual.
7. Replace the manway cover and seal. See section 4.5 (Page 11).

## 7. Winterizing

Where freezing can occur, be certain to drain the water from the filter tank prior to freezing conditions.

## 8. Graph of Filter Head Loss

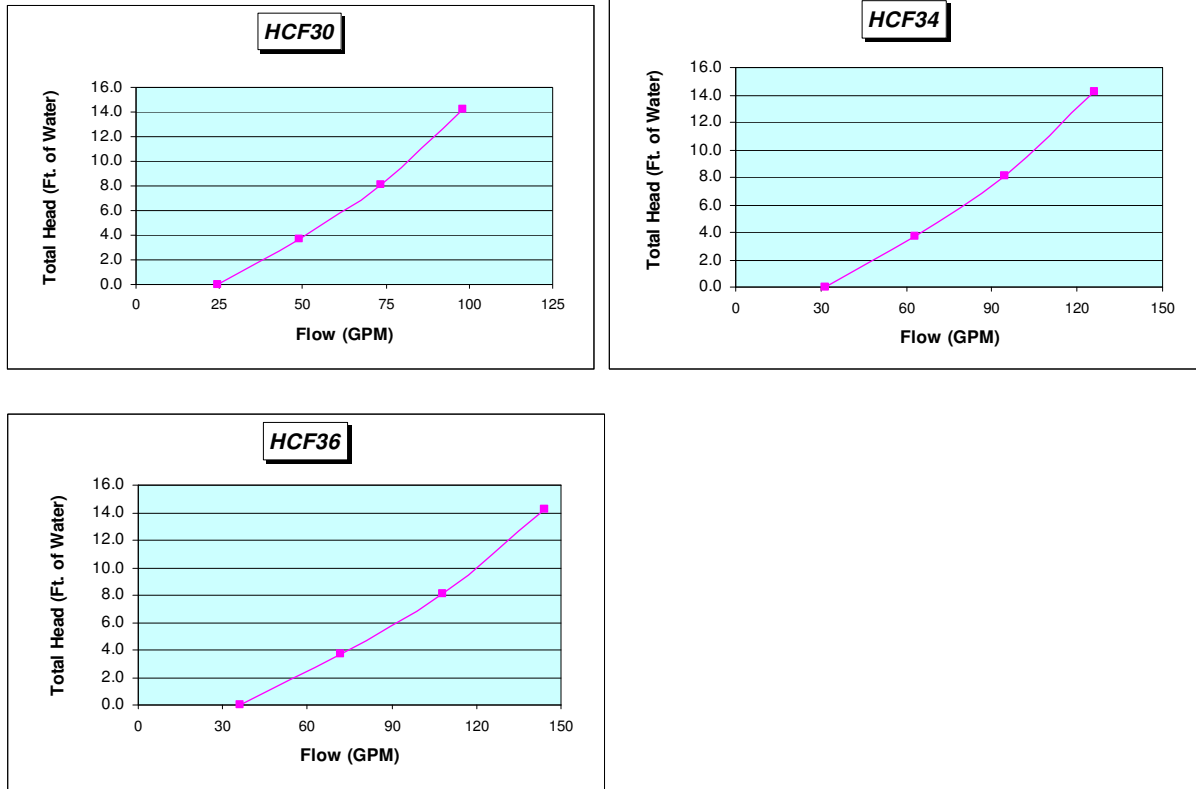

**Figure 8-1**

Acceptable Pipe Size For Maximum Recommended System Flow Rate			
<i>Pipe Size</i>	<i>Flow Rate GPM</i>	<i>Pipe Size</i>	<i>Flow Rate GPM</i>
2" (63mm)	90 (340 lpm)	4" (100mm)	350 (1325 lpm)
3" (90mm)	200 (757 lpm)	6" (150mm)	800 (3028 lpm)

## 9. Replacement Part Drawing and Numbers



Figure 9-1

## Filter Service Parts List

Item No.	Qty.	Description	Filter Model Numbers						
			HCF302T	HCF342T	HCF343T	HCF343F	HCF362T	HCF363T	HCF363F
1	1	External Air Relief Valve Assembly	HCXFARV1000	HCXFARV1000	HCXFARV1000	HCXFARV1000	HCXFARV1000	HCXFARV1000	HCXFARV1000
2	1	Pressure Gauge - 1/4" Btm Mt	HCXFPGB1000	HCXFPGB1000	HCXFPGB1000	HCXFPGB1000	HCXFPGB1000	HCXFPGB1000	HCXFPGB1000
3	1	Manway Cover Assembly	HCXFMWC1000	HCXFMWC1000	HCXFMWC1000	HCXFMWC1000	HCXFMWC1000	HCXFMWC1000	HCXFMWC1000
4	1	Manway Cover Gasket	HCXFMCG1000	HCXFMCG1000	HCXFMCG1000	HCXFMCG1000	HCXFMCG1000	HCXFMCG1000	HCXFMCG1000
5	1	Manway Cover Yoke & Knob Assy	HCXFMWY1000	HCXFMWY1000	HCXFMWY1000	HCXFMWY1000	HCXFMWY1000	HCXFMWY1000	HCXFMWY1000
6	1	Distribution Manifold Assembly	HCXFDMA1000	HCXFDMA1001	HCXFDMA1002	HCXFDMA1002	HCXFDMA1003	HCXFDMA1004	HCXFDMA1004
7	1	Internal Air Relief Assembly	HCXFARA1000	HCXFARA1001	HCXFARA1001	HCXFARA1001	HCXFARA1002	HCXFARA1002	HCXFARA1002
8	1	Collector Manifold Assembly	HCXFCMA1000	HCXFCMA1001	HCXFCMA1002	HCXFCMA1002	HCXFCMA1003	HCXFCMA1004	HCXFCMA1004
9	1	Lateral Kit	HCXFCLK1000	HCXFCLK1001	HCXFCLK1001	HCXFCLK1001	HCXFCLK1001	HCXFCLK1001	HCXFCLK1001
10	1	Drain Fitting Assembly	HCXFDFA1000	HCXFDFA1000	HCXFDFA1000	HCXFDFA1000	HCXFDFA1000	HCXFDFA1000	HCXFDFA1000
11	2	Bulkhead Fitting Assembly	HCXFBFA1000	HCXFBFA1000	HCXFBFA1001	HCXFBFA1001	HCXFBFA1000	HCXFBFA1001	HCXFBFA1001
12	2	Filter Flange Kit 3"	NA	NA	NA	HCXFFFK1000	NA	NA	HCXFFFK1000



# 10. Warranty

## Hayward® Limited Warranty

To buyer, as original purchaser of this equipment, Hayward Pool Products, 620 Division Street, Elizabeth, New Jersey, warrants its products free from defects in materials and workmanship for a period of FIVE (5) years from the date of purchase.

Parts which fail or become defective during the warranty period, except as a result of freezing, negligence, improper installation, use, or care, shall be repaired or replaced, at our option, without charge, within 90 days of the receipt of defective product, barring unforeseen delays.

To obtain warranty replacements or repair, defective components or parts should be returned, transportation paid, to the place of purchase, or to the nearest authorized Hayward service center. For further Hayward dealer or service center information, contact Hayward customer service department, or visit our website at [www.Hayward-CommercialPool.com](http://www.Hayward-CommercialPool.com) for an authorized service center near you. No returns may be made directly to the factory without the express written authorization of Hayward Pool Products.

Hayward shall not be responsible for cartage, removal and/ or reinstallation labor or any other such costs incurred in obtaining warranty replacements.

Some states do not allow a limitation on how long an implied warranty lasts, or the exclusion or limitation of incidental or consequential damages, so the above limitation or exclusion may not apply to you.

This warranty gives you specific legal rights, and you may also have other rights, which vary from state to state.

**Hayward Pool Products, 620 Division Street, Elizabeth, NJ 07207**

*\*Supersedes all previous publications*

# 11. Product Registration

DATE OF INSTALLATION \_\_\_\_\_

INITIAL PRESSURE GAUGE READING (CLEAN FILTER) \_\_\_\_\_

PUMP MODEL \_\_\_\_\_ HORSEPOWER \_\_\_\_\_

\* Retain this Warranty Certificate in safe and convenient location for your records.

# 12. Warranty Card Registration

DETACH HERE: Fill out bottom portion completely and mail within 10 days of purchase/installation or register online.

Mail to: Hayward Pool Products, 620 Division Street, Elizabeth, NJ 07207; Attention Warranty Dept Or, register your warranty online at <http://www.haywardnet.com>

Please Print Clearly:

## COMMERCIAL SAND FILTER

First Name \_\_\_\_\_ Last Name \_\_\_\_\_

Street Address \_\_\_\_\_

City \_\_\_\_\_ State \_\_\_\_\_ Zip \_\_\_\_\_

Phone Number \_\_\_\_\_ Purchase Date \_\_\_\_\_

E-Mail Address \_\_\_\_\_

Serial Number (10-17 digit number) \_\_\_\_\_

Model Number \_\_\_\_\_

Pool Capacity \_\_\_\_\_ (U.S. Gallons)

Please include me on all e-mail communications regarding Hayward® equipment or promotions.

## WARRANTY CARD REGISTRATION

Years Pool has been in service: 1 < year  1-3  6-10  11-15  >15

Purchased from \_\_\_\_\_

Builder  Retailer  Pool Service  Internet/Catalog

Company Name \_\_\_\_\_

Address \_\_\_\_\_

City \_\_\_\_\_ State \_\_\_\_\_ Zip \_\_\_\_\_

Phone \_\_\_\_\_

Type of Pool: Concrete/Gunite  Vinyl  Fiberglass  Other

New Installation  Replacement

Installation for: In-Ground  Above-Ground  Spa